

# INSTALLATION INSTRUCTIONS

Description:	<b>Voltmeter</b>	Part Number:	<b>990C0-80006/80106</b>
Applications:	<b>Suzuki Marine Boats</b>	Installation Time:	<b>1 HRS</b>
NOTE:	<b>Mounts in standard 2 1/16" hole.</b>	Weight:	<b>1 lbs</b>

## Contents

Ref.	Part Number	Description	QTY
1.	990C0-80006/80106	Voltmeter	1
2.	BC0037	Mounting Bracket	1
3.	Mounting Hardware		1

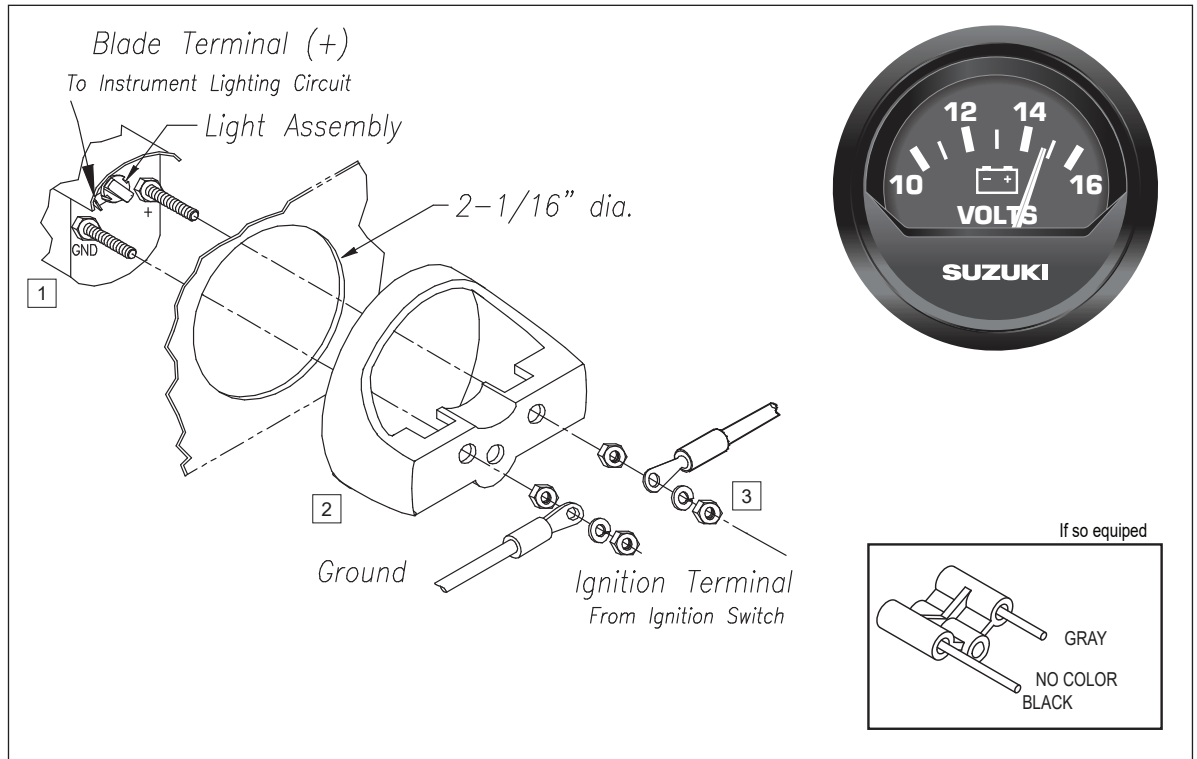

## Tools Required

Ref.	Tools Description
1.	3/8" Nut Driver



## Important

- ⚠ WARNING**
- ⚠ CAUTION**
- NOTE**

Please read this manual and follow its instructions carefully. To emphasize special information, the symbol **⚠** and the words **WARNING**, **CAUTION** and **NOTE** have special meanings. Pay special attention to the messages highlighted by these signal words:  
**NOTE:** Indicates special information to make maintenance easier or instructions clear.

**⚠ WARNING**  
 Indicates potential hazard that could result in death or injury.

**⚠ CAUTION**  
 Indicates potential hazard that could result in vehicle damage.

## ! CAUTION

- Disconnect battery during installation.
- Tighten nuts on backclamp only slightly more than you can tighten with your fingers. Six inch-pounds of torque is sufficient. Over tightening may result in damage to the instrument and may void your warranty.
- Gasket cement or other adhesive is not required to secure tubing to fittings.

## Installation

**1.** A voltmeter will read most accurately if connected to or near the switched “+” positive terminal of the ignition switch thus providing a better indication of the true battery voltage (engine off) and alternator/regulator output voltage (engine running).

**2.** Be certain to use stranded, insulated wire not lighter than 18AWG that is approved for marine use. It is recommended that insulated wire terminals, preferably ring type, be used on all connections to the gauge, except light which requires a 1/4” female blade terminal.

**3.** Cut a 2-1/16” dia hole in the dash and mount the gauge with the backclamp supplied.

**4.** Connect a wire to the gauge stud marked “+” (positive) and secure with a nut and lock washer. Connect the opposite end to a circuit that is activated by the ignition switch.

**5.** Connect a wire to the gauge stud marked “GND” (ground) and secure with a nut and lock washer. Connect the opposite end to the boat’s electrical ground, generally available in several locations at or near the instrument panel.

**6.** Connect the blade terminal adjacent to the twist-out light assembly to the positive “+” side of the instrument lighting circuit. No separate ground is required for lighting.

**7.** Reconnect the battery.

### Mounting Hardware Kit



<b>A</b>		<b>x 2</b>
<b>B</b>		<b>x 4</b>
<b>C</b>		<b>x 2</b>

Figure 1



**NOTE:** To change light bulb, twist black socket assembly one-eighth turn counterclockwise until it pops out. Bulb pulls straight out of socket assembly.

A 12V voltmeter requires a GE No. 161 instrument lamp. A 24V voltmeter requires a GE No. 657 instrument lamp.

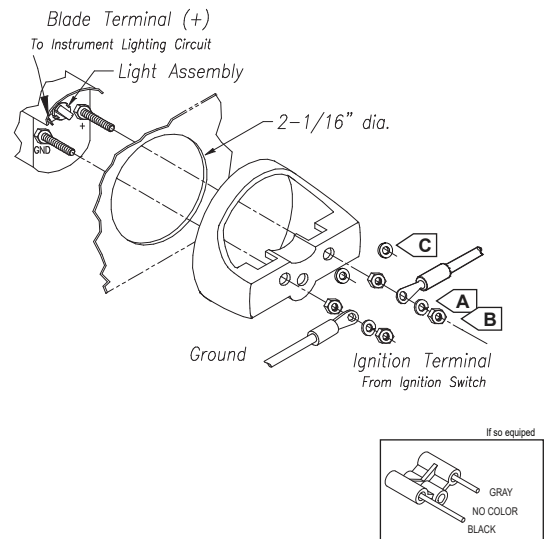

# Harness Diagram

HN0414 rev A ecr 5609 8/05

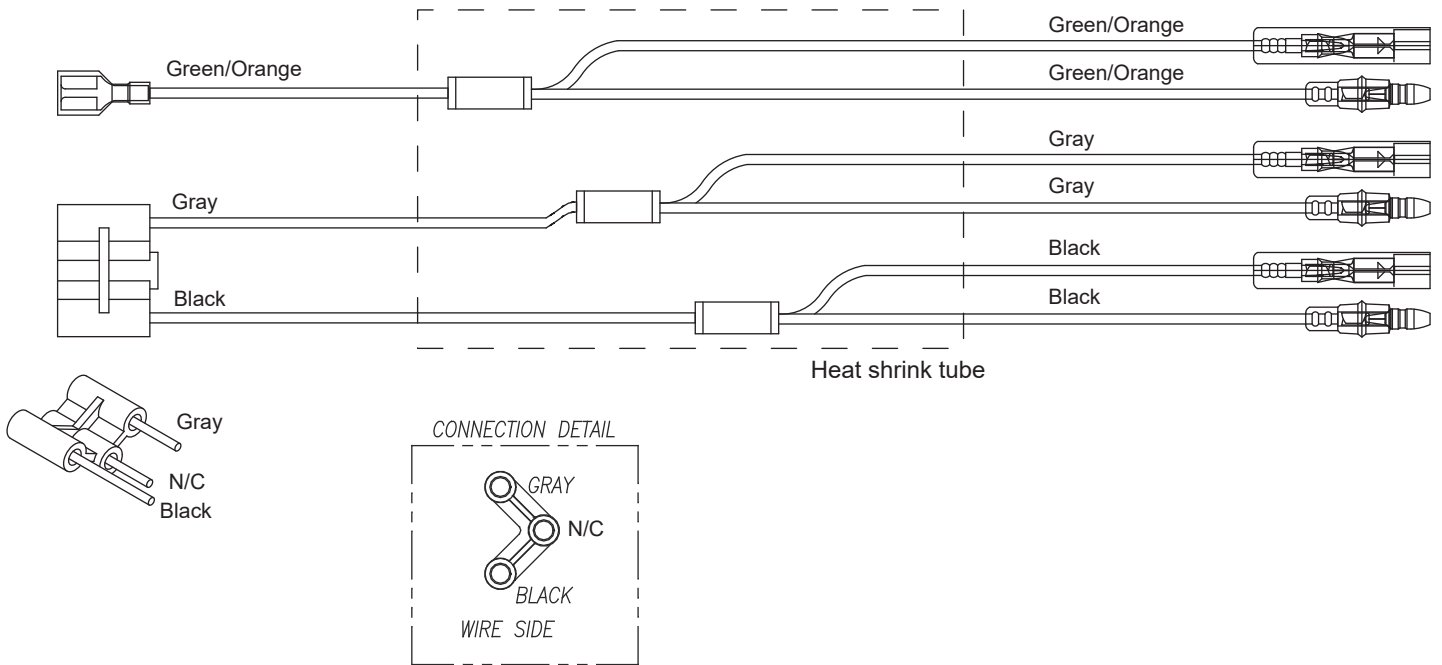

# Trouble Shooting

Trouble	Inspection	Diagnosis	Action
Gauge Sticks	A. Backclamp may be too tight.	1. Slightly loosen nuts holding backclamp. Check operation.	1. If gauge works and is not loose in panel, continue using gauge. 2. If gauge continues to stick, replace gauge.
Gauge Inoperative	A. If indications are normal (engine starts, lamps light, etc.) voltmeter reads 0.	1. Using a test voltmeter or test light, check for voltage at voltmeter.	1. If 12 volts is not present, connections are good. The problem is in the battery charging system or wiring. 2. If test voltmeter reads correct voltage, typically 14 vDC then replace voltmeter.

